

FORD FOCUS FRONT CASTER/CAMBER KIT

This part should only be installed by personnel who have the necessary skill, training and tools to do the job correctly and safely. Incorrect installation can result in personal injury, vehicle damage and / or loss of vehicle control.

Plan Ahead - Read All Instructions BEFORE installing part.

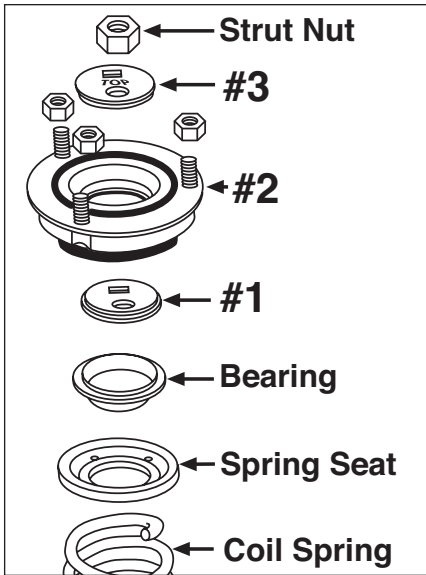

1. Always check for loose or worn parts, tire pressure, and tire wear. Determine caster/camber change needed.
2. Raise vehicle by body pinch welds. Remove tire and wheel assembly.
3. Remove strut assembly from vehicle by following manufacturer's recommended procedure.
4. Place strut assembly in strut vise, compress spring, and remove upper mounting plate. Leave spring seat on spring.
5. Remove bearing from OE strut mount and place on 81320 strut mount.
6. Install unmarked cam plate (#1) onto strut shaft with the ledge facing up. Install 81320 mount (#2) on strut shaft. Place cam plate labeled "Top" (#3) on strut shaft with the ledge facing down. Thread 12mm nut on strut shaft. Ensure that both cam plates are engaged in 81320 mount and tighten strut nut.

7. Remove strut from vise and reinstall into vehicle using manufacturer's recommended procedure. Torque 3 strut mount to fender nuts to 15 -18 lb-ft (180-215 lb-in).

CAUTION: DO NOT OVERTIGHTEN.

8. Reinstall wheel and alignment equipment, recompenstate, and lower vehicle down onto turnplates.
9. To adjust strut for camber and caster change, loosen strut nut 1/2 turn. Rotate cam plate by installing a 3/8" ratchet and extension in square hole.
10. Caster and camber correction will be determined by location of strut shaft (e.g. if strut shaft is towards engine you will get negative camber change; if strut shaft is towards front of car you will get negative caster change).
11. When adjustments are complete, torque strut nut to manufacturer's specification.

Always check for proper clearance between suspension components and other components of the vehicle.

12. Recheck alignment readings and road test vehicle.

**Specialty Products Company**[®]

P.O. Box 923 • Longmont, CO 80502 • (303) 772-2103 • Fax: (303) 772-1918
www.specprod.com • www.spcperformance.com • Email: info@specprod.com

Toll Free Technical Hot Line: 1-800-525-6505

ECN#1837

©2015 Specialty Products Company • Printed in U.S.A. • Form No. 98320 • Rev. 5/15