



**Instruction sheet  
Adjustable Rear Arm**

*This part should only be installed by personnel who have the necessary skill, training and tools to do the job correctly and safely. Incorrect installation can result in personal injury, vehicle damage and / or loss of vehicle control.*

**Plan Ahead - Read All Instructions BEFORE installing part.**

Check for loose or worn parts, proper tire pressure, and odd tire wear patterns before beginning alignment.

1. Raise rear of vehicle and properly support directly under coil springs. This will keep suspension loaded. Remove rear wheel and tire assembly.
2. Remove inner and outer bolts of upper control arm and remove OE arm.
3. Adjust SPC control arm to approximately the same length as OE arm.  
**NOTE: Thread small jam nut so it is closest to bushing side of rod. Ensure equal thread is showing before and after large adjuster nut.**

4. Install control arm using OE hardware and lightly tighten both mounting bolts.  
**WARNING: Tightening fasteners with vehicle in raised position may cause premature bushing failure.**

5. Install tire and wheel assembly and lower vehicle.

6. Adjust camber by turning large adjusting nut to achieve desired camber specification.

**NOTE: It may be necessary to remove nut on sway bar link and move sway bar out of the way.**

**NOTE: Maximum length of arm is reached when thread on either side of the adjusting nut is 1/2" (12.7 mm), see Figure 1. DO NOT lengthen arm beyond this point. Exceeding range of adjustment on arm may cause it to fail and voids warranty.**

7. After adjustment is complete, tighten pinch bolt to 20 ft-lb [27 Nm]. Tighten small jam nut tightly against large adjuster nut. Torque OE mounting bolts to manufacturer's specifications.

**NOTE: Additional camber can be attained by using OE camber adjusting bolts.**

8. Complete vehicle alignment and road test vehicle.

**Always check for proper clearance between suspension components and other components of vehicle.**

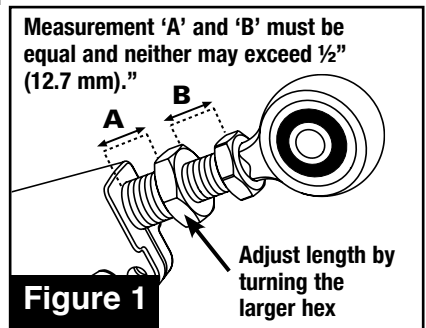

**Specialty Products Company®**

4045 Specialty Place • Longmont, CO 80504 • (303) 772-2103 • Fax: (303) 772-1918 www.specprod.com • Email: info@specprod.com • Toll Free Technical Hot Line: 1-800-525-6505

©2023 Niwot Corp. dba Specialty Products Co® • Printed in U.S.A. • Form No. 67440INS • Rev. 01/23 ECN#3264