



**Instruction sheet
ADJUSTABLE REAR ARMS**

This part should only be installed by personnel who have the necessary skill, training and tools to do the job correctly and safely. Incorrect installation can result in personal injury, vehicle damage and / or loss of vehicle control.

Check for loose or worn parts, proper tire pressure, and odd tire wear patterns before beginning alignment.

1. Take alignment readings and determine amount of camber change needed.
2. Raise vehicle and support by frame so suspension hangs free. Remove rear tire and wheel assembly.

TECH TIP: Mount and zero SPC P/N 81139 magnetic camber gauge to brake rotor.

3. Remove OE rear upper control arm per manufacturer's procedure.
4. Before installing SPC upper control arm, adjust it to approximately same length as OE arm. Ensure equal threads are visible beyond end of control arm and beyond jam nut when it is fully seated.
5. Install arm. Loosely tighten mounting bolts on each end of arm, but do not torque bolts while vehicle is still lifted.

NOTE: Tightening bushing fasteners with vehicle in raised position may cause premature bushing failure.

6. Adjust control arm to desired camber setting by rotating center hex adjuster.

TECH TIP: If using magnetic camber gauge, verify change and adjust length if necessary.

Note: Threads visible should not exceed 13mm (1/2") each side. (Figure 1.)

Exceeding the range of adjustment of these arms may cause the arm to fail and void warranty.

7. When desired camber change is achieved, tighten jam nuts against hex adjuster and tighten small pinch bolt to 20 lb-ft to lock setting.
8. Reinstall tire and wheel assembly and lower vehicle. Settle suspension to normal ride height.
9. Torque control arm bolts to manufacturer's specification.
10. Confirm camber change and adjust rear toe. Complete alignment and road test vehicle.

**Always check for proper clearance
between suspension components and other
components of the vehicle.**

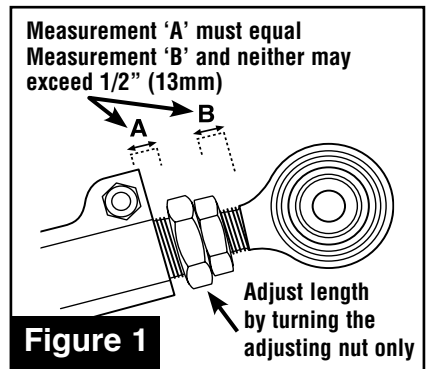

Specialty Products Company®

4045 Specialty Place • Longmont, CO 80504 • (303) 772-2103 • Fax: (303) 772-1918
www.specprod.com • Email: info@specprod.com • **Toll Free Technical Hot Line: 1-800-525-6505**

For warranty information go to: www.specprod.com/warranties

ECN#3034