

PATENT NO. US 7,513,514 B1

**TOYOTA ADJUSTABLE CAMBER/CASTER UPPER ARMS**

**Toyota Tundra, Sequoia**

*This part should only be installed by personnel who have the necessary skill, training and tools to do the job correctly and safely. Incorrect installation can result in personal injury, vehicle damage and / or loss of vehicle control.*



Check out how to install this part at: <http://www.spc-tv.com>

**Plan Ahead - Read All Instructions BEFORE installing part.**

Check for loose or worn parts, proper tire pressure, and odd tire wear patterns before beginning alignment.

1. If your vehicle is equipped with ride height sensors first measure front ride height.
2. Raise vehicle by frame and support with jack stands. Remove front tire and wheel assemblies.
3. Loosen nut on the upper arm-to-frame mounting bolt and remove bolt holding ABS wiring from upper arm. Remove ride height sensor from arm if equipped.
4. Remove cotter pin and nut holding OEM ball joint to knuckle. Break the taper between the ball joint stud and knuckle and remove the ball joint from the knuckle. Support the knuckle so no strain is applied to ABS wiring or brake lines.
5. Remove nut and washer from long arm-to-frame mounting bolt and remove bolt and arm.

**NOTE: To provide clearance, additional components in the engine compartment may need to be removed.**

6. Install SPC control arm on vehicle. Place one large washer on bolt before insertion, and second large washer just before the nut. Orient washers as shown in (Figure 1 and 2), allowing free space between bushing bumpers and washer. Torque to manufacturer's specifications.

**NOTES: 1) The stock 'dished' washers are not re-used.**

**2) Unlike OE rubber bushings, xAxis™ bushings pivot freely and can be torqued without applying vehicle weight.**

7. Install star plate over hex on ball joint per chart below to achieve desired caster change relative to the stock arm. (For most trucks with 2-3" of lift, setting "D" should return caster to manufacturer's specifications, but it may be necessary to use different positions on each side to achieve desired cross-caster setting.) Insert

8. Insert ball joint stud into the knuckle, install the supplied castle nut and torque to 45 ft-lb [61Nm]. Tighten further until the supplied cotter can be installed.
9. Re-attach the ABS wiring bracket to the SPC arm using the OE bolt. If equipped, re-attach ride height sensor to arm bracket.
10. Grease ball joint with an **NLGi #2, Grade LB with 3%-5% Molybdenum Disulfide grease**. 5 to 10 pumps of grease is sufficient at each lubrication.

**WARNING: FAILURE TO GREASE AND MAINTAIN THIS BALL JOINT MAY RESULT IN PREMATURE FAILURE.**

11. Re-install tire and wheel assembly. Lower the vehicle.

**NOTE: On vehicles with ride height sensors it may be necessary to adjust sensor linkage to achieve desired ride height after adjustable arm is installed.**

12. Take alignment readings. Adjust camber by loosening top nut and sliding ball joint in control arm slot. Adjust caster by loosening top nut and repositioning star plate to rotate ball joint relative to arm. (It will be necessary to raise vehicle to make these adjustments.)
13. When final caster/camber settings are achieved, torque top ball joint nut to 150 ft-lb [203Nm]. Adjust toe and road test vehicle.

**Always check for proper clearance between suspension components and other components of the vehicle. Camber and caster can be set with the SPC upper control arm, as well as the OEM lower control arm eccentric bolts. In most cases, it is recommended that lower eccentric bolts be set to their neutral position. This way they can be used to fine-tune caster. However, to maximize tire clearance at rear of wheel opening set caster for maximum with the OEM lower cams and fine tune alignment setting with SPC upper control arm.**

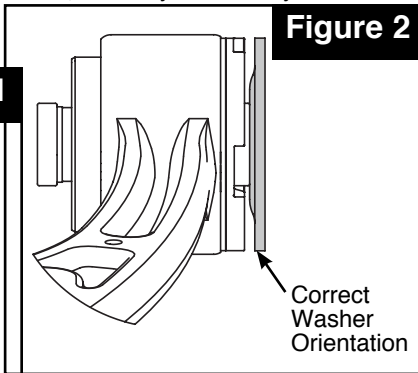
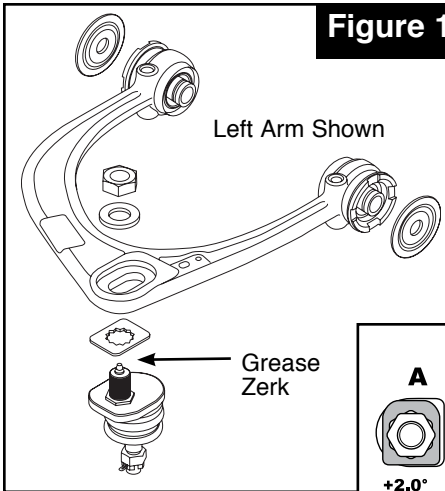

Check out how to move tire forward in wheel well at <http://www.spc-tv.com>

**Maintenance:**  
Lubrication Interval - SPC recommends adding 5 to 10 pumps of grease to ball joint at each oil change, or after operating vehicle in wet or dusty conditions.

**Note: With SPC logo facing the tire (Position D) this arm will give +1° additional caster. Using the star plate, caster change can be adjusted from -1.0° to +3.0°.**

LEFT FRONT CASTER CHANGE							FRONT OF VEHICLE
A	B	C	D	E	F	G	
							Ball Joint Setting
+2.0°	+1.75°	+1.0°	0°	-1.0°	-1.75°	-2.0°	
<b>+3.0°</b>	<b>+2.75°</b>	<b>+2.0°</b>	<b>+1.0°</b>	<b>0.0°</b>	<b>-.75°</b>	<b>-1.0°</b>	<b>Total Arm + Ball Joint Caster Change</b>
RIGHT FRONT CASTER CHANGE							FRONT OF VEHICLE
A	B	C	D	E	F	G	
							Ball Joint Setting
+2.0°	+1.75°	+1.0°	0°	-1.0°	-1.75°	-2.0°	
<b>+3.0°</b>	<b>+2.75°</b>	<b>+2.0°</b>	<b>+1.0°</b>	<b>0.0°</b>	<b>-.75°</b>	<b>-1.0°</b>	<b>Total Arm + Ball Joint Caster Change</b>



**Specialty Products Company®**

4045 Specialty Pl. • Longmont, CO 80504 • (303) 772-2103 • Fax: (303) 772-1918 • [www.specprod.com](http://www.specprod.com) • Email: [info@specprod.com](mailto:info@specprod.com)

**Toll Free Technical Hot Line: 1-800-525-6505**

©2022 Niwot Corp. dba Specialty Products Co.® • Printed in U.S.A. • Form No. 984901 • Rev. 04/22 ECN#3114